

PRODUCT SPECIFICATIONS

Halsey Taylor Outdoor Endura™ Pedestal Fountain Non-Filtered Non-Refrigerated Freeze Resistant. Features shall include Freeze Resistant. Furnished with Vandal Resistant bubbler. Mechanical Front Bubbler Button activation. Product shall be Floor Mount/Freestanding, for Outdoor applications, serving 1 station(s). Unit shall be lead-free design which is certified to NSF/ANSI 61 & 372 (lead free) and meets Federal and State low-lead requirements.

Order ID:	7604715216
Special Features:	Freeze Resistant
Finish:	Blue (BLU)
Power:	No Electrical Required
Bubbler Style:	Vandal Resistant
Activation by:	Mechanical Front Bubbler Button
Mounting Type:	Floor Mount/Freestanding
Chilling Capacity:	Non-refrigerated
Dimensions (L x W x H):	14" x 12" x 39-1/2"
Approx. Shipping Weight:	81 lbs.
Installation Location:	Outdoor
No. of Stations Served:	1

**When used in non-temperature controlled environments, unit(s) must be adequately winterized and/or protected from extreme heat to prevent damage where climates dictate.

- Mechanically-Activated bubbler continues to supply water in event of service disruptions.
- Freeze Resistant:
- Depending on specific installation, freeze resistant system is located either below frost line or in temperature controlled space.

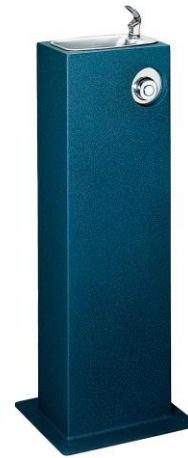

Included with Product: Outdoor Fountain, Freeze Resistant Valve Assembly

Ships in multiple boxes.

AMERICAN PRIDE. A LIFETIME TRADITION. Like your family, the Elkay family has values and traditions that endure. For almost a century, Elkay has been a family-owned and operated company, providing thousands of jobs that support our families and communities.



PRODUCT COMPLIANCE

ASME A112.19.3/CSA B45.4
Buy American Act
NSF/ANSI 61 & 372 (lead free)



[Installation Instructions \(PDF\)](#)

Warranty pertains to drinking water applications only. Non-drinking water applications are not covered under warranty.

[Warranty \(PDF\)](#)

PART: _____ QTY: _____

PROJECT: _____

CONTACT: _____

DATE: _____

NOTES: _____

APPROVAL: _____

In keeping with our policy of continuing product improvement, Halsey Taylor reserves the right to change product specifications without notice. Please visit Halseytaylor.com for the most current version of Halsey Taylor product specification sheets. This specification describes a Halsey Taylor product with design, quality, and functional benefits to the user. When making a comparison of other producers' offerings, be certain these features are not overlooked.

MOUNTING INSTRUCTIONS and PLUMBING INSTRUCTIONS

Site and drainage excavation is required for fountain installation. Refer to owner's manual for site preparation details. Provide solid, well-drained surface to mount pedestal fountain (concrete pad recommended) with adequate support (300 lb. load minimum). (6) 3/8" minimum fasteners (not included) should be attached securely to mounting surface in order to secure fountain, (Refer to rough-in diagram), and be sure to allow an opening for the freeze-resistant valve in the ground as shown in the installation instructions that accompany the fountain. (Refer to the rough-in diagram below). Refer to local codes for any additional requirements.

Locate and install plumbing through ground as required. Assemble fountain to prepared site and mounting pad.

NOTE: Fountain is not furnished with service valve. Position pedestal over plumbing and secure base to fasteners. Remove access panels and connect supply and water lines. Turn on water supply and check for leaks. Refer to owner's manual for detailed instructions. Reassemble access panels to pedestal. Trap and service stop not included.

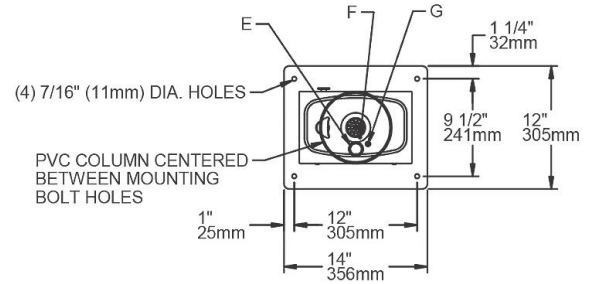

SITE PREPARATION DETAIL

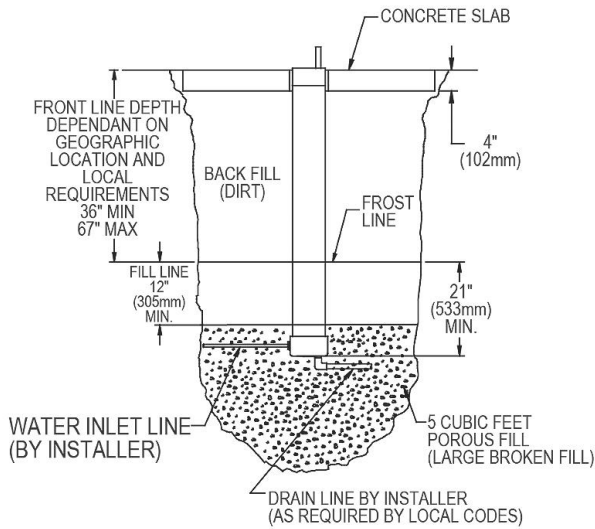

LEGEND

- A = Access panel.
- B = 1" (25.4mm) PVC drain.
- C = Pressure fitting 1-1/4" (32mm) x 3/4" (19mm).
- D = Connector 1-1/4" (32mm) to 1-1/4" (32mm).
- E = 1-1/4" (32mm) drain tube.
- F = Air control line.
- G = 1/4" (6mm) water line.
- H = Connector for air control line.

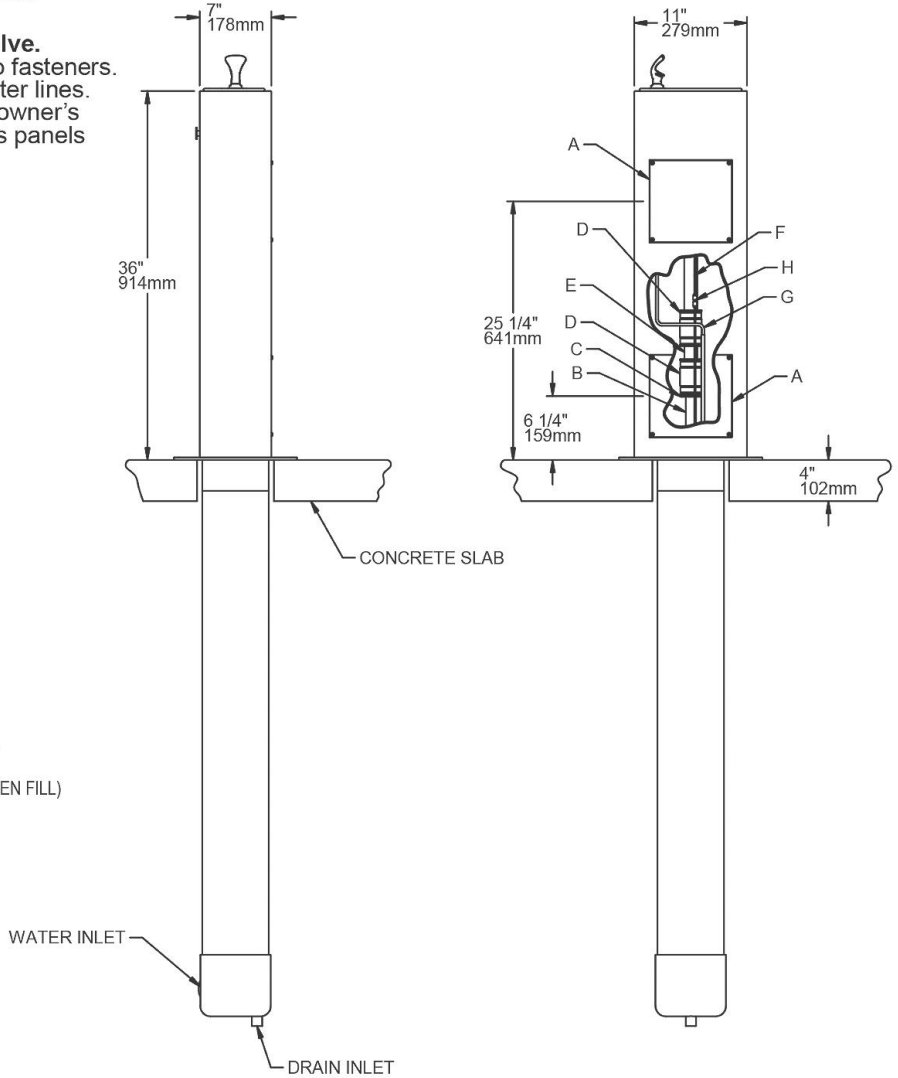

In keeping with our policy of continuing product improvement, Halsey Taylor reserves the right to change product specifications without notice. Please visit Halseytaylor.com for the most current version of Halsey Taylor product specification sheets. This specification describes a Halsey Taylor product with design, quality, and functional benefits to the user. When making a comparison of other producers' offerings, be certain these features are not overlooked.